



The Dudley Tri-Well cistern is designed to be supported by wall brackets. Please note these brackets are not supplied with the cistern kit. Do not drill the cistern body for screw fixing. The water supply to the cistern must be on the same side as the pull chain lever but can be left or right hand fitting with respect to the front of the cistern. Overflow warning can be internal (overflowing into the pan) or via an external pipe connection.

The Dudley S1-11 Turbo 2-part syphon is **factory set to deliver 9 litres** to the WC pan but can be adjusted to deliver 6 or 7 litres.

### WARNING

**No sealing compound, paste, flux or solvent to be used in contact with plastic or rubber surfaces, to avoid damage to plastic components. Rubber washers should provide adequate seal. PTFE tape may be used on threads. Do not overtighten plastic nuts.**

#### Fitting the syphon to the cistern.

Determine the required flush quantity (6, 7 or 9 litres) which is needed to be delivered to the WC pan.

Adjust the syphon as follows: see **1**

**For 6 litres** - Remove the **upper white plug only** in the syphon body.

**For 7 litres** - Remove the **lower white plug only** in the syphon body.

Fit the syphon with the rubber washer inside the cistern and secure with backnut. Make sure the operating link is nearest the cistern end where the pull chain lever is to be fitted. See **2**

#### Fitting the inlet valve.

The side inlet valve is factory fitted with a 3mm bore high pressure (white) seat. If the supply water is tank fed this seat must be replaced with the red seat attached to the arm of the valve. To change the seat, rotate the front nut anticlockwise until it disengages with the valve body. Remove the Plunger and diaphragm. Remove the diaphragm support cage. The seat can now be easily removed from the assembly. Make sure the 'O' ring, under the seat, is in its groove before fitting the new seat. Assemble other components in reverse order. The front nut should be hand tight. Do not over tighten. See **9**

#### Fit the Inlet valve to the cistern.

Remove one of the spigoted nuts from the valve body and make sure the remaining nut is orientated so the spigot on the nut is facing towards the cistern wall. Offer the valve to the cistern and pass the thread through the wall and locate the nut spigot into the hole to centralise valve. Replace the other nut onto the thread with the spigot facing the cistern wall. Before tightening, make sure there is sufficient thread protruding beyond the outer nut so the supply pipe can be fitted. Tighten outer nut making sure the valve arm is moving freely in a vertical direction. Attach the ball float to the end of the arm and position it using the joint so that it is free to move vertically and does not touch the walls of the cistern or the syphon. See **3**

#### Internal / External warning.

If Internal warning is required fit the blanking plug provided into the side hole opposite to the inlet valve fitting as per diagram.

If external warning is required, fit the side overflow fitting supplied into the side hole opposite to the inlet valve fitting, ready for external pipe to be fitted. See **4**

#### Fit lever to cistern.

Take fulcrum bracket and fit to cistern via dovetail slot in side of cistern body. Secure by means of the screw and nut provided. See **5**

Hook the 'C' clip, on the syphon, through the hole in the lever and fit pegs on lever into holes in fulcrum bracket. Operate lever to make sure of smooth action.

#### Installing cistern assembly.

With the cistern support brackets fixed at the required height, place the cistern on the brackets and connect pipework for water inlet and external warning (if required). Connect the flush pipe to the cistern using the cone ring and capnut supplied. No more than 50mm to be inserted into tail of syphon. See **6**

If splashing occurs from the pan rim, fit the pan restrictor washer (supplied) into the pan inlet before connecting the flush pipe to the pan.

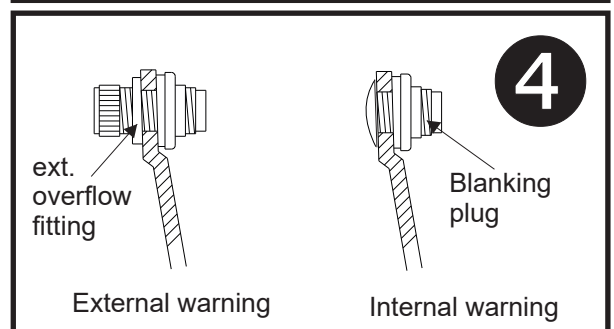
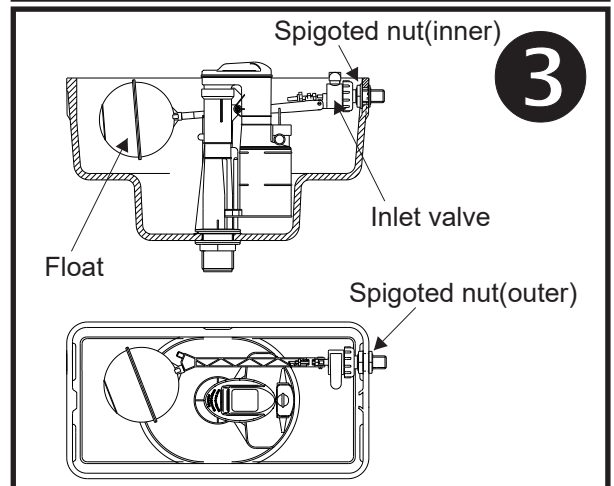
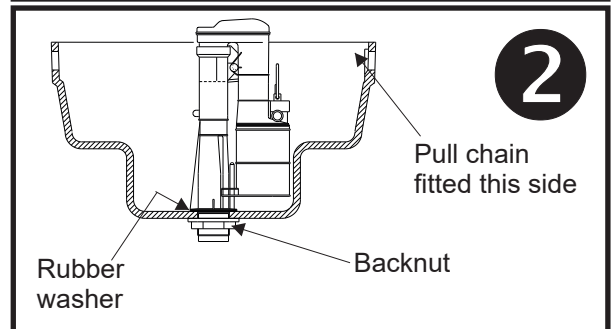
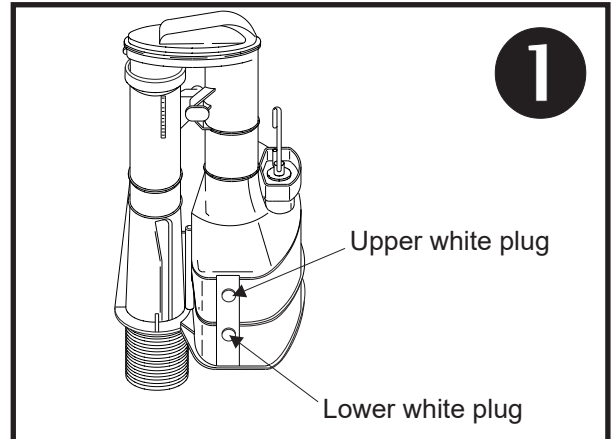

### Setting the water level.

Turn on the water supply and set the ball valve arm so that the water level is initially 13mm (1/2") below level marked on the inside wall of the cistern and secure with the locknut.

Check all joints for leakage.

Flush the cistern several times to ensure efficient flushing. If overflowing or poor flushing occurs, first check that the float arm moves freely up and down. If not, reset and secure in position. If the valve does not shut off at the required level, after setting, turn off water supply and check internal valve parts and remove any foreign matter.

### Fit cistern cover.

Take the cistern cover and fit to cistern body with the cutout adjacent to the operating lever. Secure lid with two self tapping screws, either end of lid. See **7**

### Fit the chain pull.

With two pairs of pliers, bend the connection hook on the chain open sufficiently so as to be able to attach hook through the hole in the lever. After connection bend hook back to its original position so that the chain pull can not be removed from the cistern lever.

### Servicing the syphon.

The unique feature of the Dudley Turbo 1-11 syphon is that you need not turn off the water supply to service it. If replacement parts need to be used, service packs of piston parts are available from your local builders merchants.

To remove the syphon body from its down leg, first disconnect the link from the lever. Remove the yellow snap pin by pulling it side ways and then pull vertically on the syphon body. The body will become detached from the down leg. By removing the 'C' link from the piston rod the whole of the piston assembly can be removed from the body. To replace the diaphragm, lever the retaining bracket off the two pegs on the piston plate and remove diaphragm. Reassemble the syphon in the reverse order. See **8**

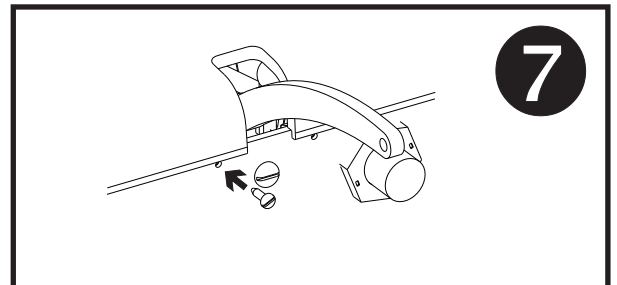
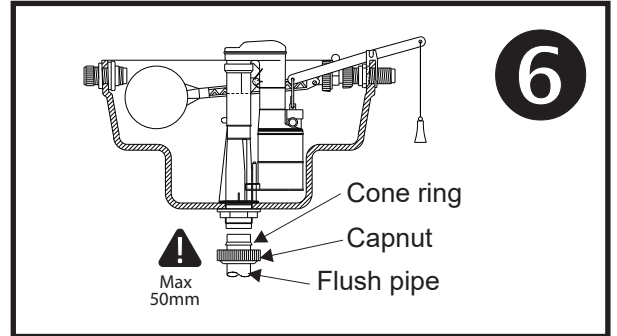
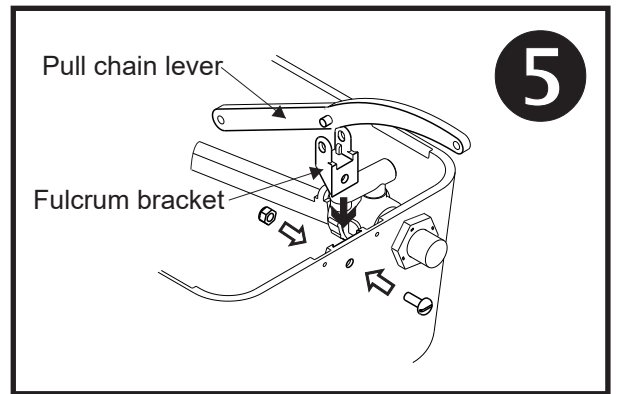

### FINAL CHECK LIST

Before turning on water supply check :-

**CISTERN IS SECURE -  
ALL MOVING COMPONENTS OPERATE FREELY -  
ALL JOINTS ARE TIGHTENED CORRECTLY**

Now fill cistern and set water level.

**CHECK CAREFULLY FOR LEAKS -  
ENSURE ALL MOVING COMPONENTS OPERATE FREELY -  
CHECK FLOAT ARM MOVES FREELY UP AND DOWN AND  
CLOSES OFF CORRECTLY -  
TEST SYPHON OPERATION AND THAT CISTERN FLUSHES  
CORRECTLY**

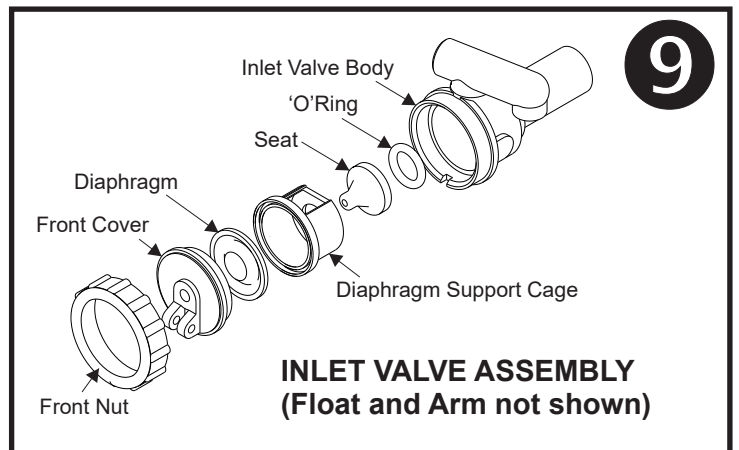
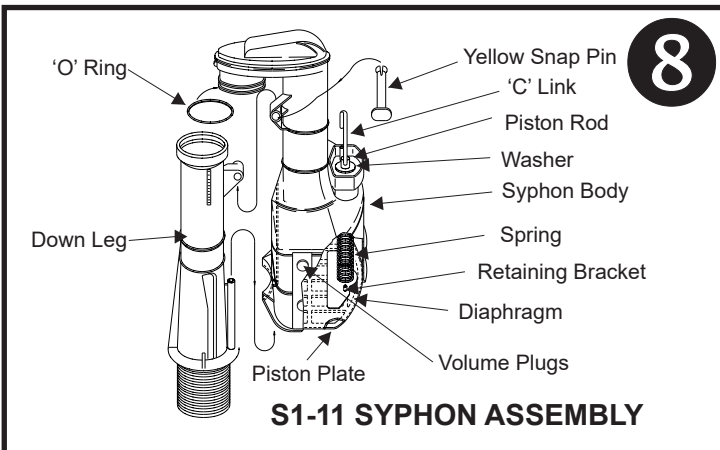

We reserve the right to revise this specification and details without notice.

TDCF 1262 iss. D

Thomas Dudley  
295 Birmingham New Road  
Dudley, West Midlands  
United Kingdom  
DY1 4SJ

t +44 (0)121 557 5411  
f +44 (0)121 557 5345  
e info@thomasdudley.co.uk  
w www.thomasdudley.co.uk/plumbing

THOMAS  
DUDLEY

